

FALCOM C2D-SI

User Manual



Contents

0	INTRODUCTION	3
0.1	GENERAL	3
0.2	USED ABBREVIATIONS	3
0.3	RELATED DOCUMENTS	5
1	SECURITY	6
1.1	GENERAL INFORMATION	6
1.2	EXPOSURE TO RF ENERGY	6
1.3	EFFICIENT MODEM OPERATION	6
1.4	ANTENNA CARE AND REPLACEMENT	7
1.5	DRIVING	7
1.6	ELECTRONIC DEVICES	7
1.7	VEHICLE ELECTRONIC EQUIPMENT	7
1.8	MEDICAL ELECTRONIC EQUIPMENT	7
1.9	AIRCRAFT	7
1.10	CHILDREN	8
1.11	BLASTING AREAS	8
1.12	POTENTIALLY EXPLOSIVE ATMOSPHERES	8
1.13	NON-IONISING RADIATION	8
2	SAFETY STANDARDS	9
3	TECHNICAL DATA	10
3.1	PIN CONFIGURATION OF THE 60 PIN CONNECTOR	13
3.1.1	Determining the External Equipment Type	15
4	GSM MODEM	17
4.1	GENERAL	17
4.1.1	GSM capability	17
4.1.2	GPRS capability	17
4.1.3	GSM data services	17
4.1.4	RF characteristics	17
4.1.5	SIM card reader	18
4.1.6	RS 232	18
4.1.7	Possible external devices	18
4.2	SPECIAL FUNCTIONALITY PINS	19
4.2.1	Firmware download procedure	23
4.2.2	Resetting the GSM module by AT+CFUN=1,1	23
4.3	GSM 07.05 AND 07.07 COMMANDS	23
4.3.1	General AT commands	24
4.3.2	SMS AT commands (GSM 07.05)	25
5	GPS CORE	26
5.1	RECEIVER ARCHITECTURE	26
5.2	TECHNICAL DATA	27
5.3	TECHNICAL DESCRIPTION	29
5.3.1	Technical specification	29
5.4	HARDWARE INTERFACE	30
5.4.1	Configuration and timing signals	30
5.4.2	Serial communication signals	30
5.4.3	DC input signals	31
5.4.4	General purpose input/output (Pin 51, 53, 54 and 56)	31
5.5	SOFTWARE INTERFACE	31
5.5.1	SiRF binary data message	31
5.5.2	NMEA data message	34

6	HOUSING	36
7	GSM/GPS EVALUATION KIT	37
8	EMC AND ESD REQUIREMENTS.....	39
9	CE CONFORMITY	40

Version history

Version number	Author	Changes
1.00	Sameh Awad	Initial version
1.01	S. Mohamad	<ul style="list-style-type: none"> - Fixing points (holes) described - Counterpart for the 60 pin connector added
1.02	F. Beqiri	<ul style="list-style-type: none"> - Housing, AT-Commands, Temperature limits, Pin configuration.
1.03	F. Beqiri	<ul style="list-style-type: none"> - Pictures of C2D-SI module changed - Description of pin 15 corrected.
1.04	F. Beqiri	<ul style="list-style-type: none"> - Hint in Trickle Power Mode added
1.05	F. Beqiri	<ul style="list-style-type: none"> - Description of pin 15 corrected.
1.06	F. Beqiri	<ul style="list-style-type: none"> - Description of pin 18 (VCCRTC) backup battery power completed. - Table 3 power consumption for C2D-SI updated. - Table 4 power consumption for C2D-SI-G10 added. - Power consumption of GPS receiver updated.
1.07	F. Beqiri	<ul style="list-style-type: none"> - Determination for DCE-DTE connection (Chapter 3.1.1) added. - Based on the DCE-DTE connection the name of RX and TX (from GSM core) signals in the table 7 updated. The name of RxA, TxA and RxB, TxB (from GPS core) updated, too. - Mechanical dimensions of module updated.

0 Introduction

0.1 General

This description is focussed on the GSM/GPS module FALCOM C2D-SI from the FALCOM GmbH. It contains short information about purpose and use of the FALCOM C2D-SI. The FALCOM C2D-SI is a combined GSM/GPRS¹⁾ / GPS module. It contains dual band GSM and 12 parallel channel GPS cores.

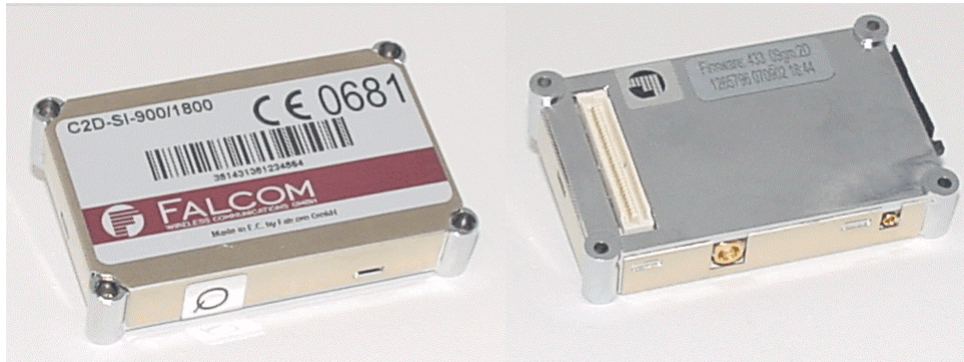

Figure 1: Views of FALCOM C2D-SI

Information furnished herein by FALCOM GmbH is believed to be accurate and reliable. However, no responsibility is assumed for its use. Also the information contained herein is subject to change without notice. Users are advised to proceed quickly to the „Security“ chapter and read the hints carefully.

1) The FALCOM C2D-SI is GPRS capable.

- GPRS packet data features:
- GPRS Class B, Class 10
- Coding Schemes: CS1 to CS4
- Compliant with SMG32 – Release 97

Note that the GPRS functionality is a subject of the implementation of the current GSM/GPRS firmware.

0.2 Used abbreviations

Abbreviation	Description
CTS	Clear to send
DGPS	Differential GPS
DOP	Dilution of Precision

Abbreviation	Description
DSR	Data Set Ready
DTR	Data Terminal Ready
DCD	Data Carrier Detect
ECEF	Earth-Centered Earth-Fixed Co-ordinate system
EEPROM	Memory for parameter
EGSM	Enhanced GSM
ESD	Electrostatic Discharge
ETS	European Telecommunication Standard
GPRS	General Packet Radio Service
GPS	Global Positioning System
GSM	Global Standard for Mobile Communications
GGA	GPS Fixed Data
HDOP	Horizontal DOP
HW	Hardware
IMEI	International Mobile Equipment Identity
I/O	Input/Output
NMEA	National Marine Electronics Association
PRN	Pseudorandom Noise Number – The Identity of GPS satellites
RF	Radio Frequency
RI	Ring Indication
RTC	Real Time Clock
RTCM	Radio Technical Commission for Maritime Services
RTS	Ready To Send
Rx	Receive direction
RXD	Data input
RXQUAL	Received Signal Quality

Abbreviation	Description
SIM	Subscriber Identification Module
SMS	Short Message Service
SRAM	Static Random Access Memory
SW	Software
TA	Terminal Adapter
TE	Terminal Equipment
TP	Transmit Protocol
TTF	Time to First Fix
Tx	Transmit direction
TXD	Data output
SA	Selective Availability
WAAS	Wide Area Augmentation System
MSK	Minimum Shift Keying

Table 1: Used abbreviations

0.3 Related documents

1. ETSI GSM 07.05:“Use of Data Terminal Equipment–Data Circuit terminating Equipment interface for Short Message Service and Cell Broadcast Service”
2. ETSI GSM 07.07“AT command set for GSM Mobile Equipment”
3. ITU-T V.25ter“Serial asynchronous automatic dialling and control”
4. SiRF binary and NMEA protocol specification;
www.falcom.de/Service/Manuals
5. “AT commands interface for FALCOM A2D, A2D-JP, A2D-SI, C2D, C2D-SI and A3D- Series”.
www.falcom.de/Service/Manuals

1 Security

IMPORTANT FOR THE EFFICIENT AND SAFE OPERATION OF YOUR GSM-MODEM, READ THIS INFORMATION BEFORE USE!

Your cellular engine FALCOM C2D-SI is one of the most exciting and innovative electronic products ever developed. With it you can stay in contact with your office, your home, emergency services and others, wherever service is provided.

This chapter contains important information for the safe and reliable use of the FALCOM C2D-SI. Please read this chapter carefully before starting to use the cellular engine FALCOM C2D-SI.

1.1 General information

Your FALCOM C2D-SI modem utilises the GSM/GPRS standard for cellular technology. GSM is a newer radio frequency („RF“) technology than the current FM technology that has been used for radio communications for decades. The GSM standard has been established for use in the European community and elsewhere. Your modem is actually a low power radio transmitter and receiver. It sends out and receives radio frequency energy. When you use your modem, the cellular system handling your calls controls both the radio frequency and the power level of your cellular modem.

1.2 Exposure to RF energy

There has been some public concern about possible health effects of using GSM modem. Although research on health effects from RF energy has focused for many years on the current RF technology, scientists have begun research regarding newer radio technologies, such as GSM. After existing research had been reviewed, and after compliance to all applicable safety standards had been tested, it has been concluded that the product is fit for use.

If you are concerned about exposure to RF energy there are things you can do to minimise exposure. Obviously, limiting the duration of your calls will reduce your exposure to RF energy. In addition, you can reduce RF exposure by operating your cellular modem efficiently by following the guidelines below.

1.3 Efficient modem operation

In order to operate your modem at the lowest power level, consistent with satisfactory call quality please take note of the following hints.

- If your modem has an extendible antenna, extend it fully. Some models allow you to place a call with the antenna retracted. However your modem operates more efficiently with the antenna fully extended.
- Do not hold the antenna when the modem is „IN USE“. Holding the antenna affects call quality and may cause the modem to operate at a higher power level than needed.

1.4 Antenna care and replacement

Do not use the modem with a damaged antenna. If a damaged antenna comes into contact with the skin, a minor burn may result. Replace a damaged antenna immediately. Consult your manual to see if you may change the antenna yourself. If so, use only a manufacturer-approved antenna. Otherwise, have your antenna repaired by a qualified technician.

Use only the supplied or approved antenna. Unauthorised antennas, modifications or attachments could damage the modem and may contravene local RF emission regulations or invalidate type approval.

1.5 Driving

Check the laws and regulations on the use of cellular devices in the area where you drive. Always obey them. Also, when using your modem while driving, please pay full attention to driving, pull off the road and park before making or answering a call if driving conditions so require. When applications are prepared for mobile use they should fulfil road-safety instructions of the current law!

1.6 Electronic devices

Most electronic equipment, for example in hospitals and motor vehicles is shielded from RF energy. However RF energy may affect some malfunctioning or improperly shielded electronic equipment.

1.7 Vehicle electronic equipment

Check your vehicle manufacturer's representative to determine if any on board electronic equipment is adequately shielded from RF energy.

1.8 Medical electronic equipment

Consult the manufacturer of any personal medical devices (such as pacemakers, hearing aids, etc.) to determine if they are adequately shielded from external RF energy.

Turn your FALCOM C2D-SI modem OFF in health care facilities when any regulations posted in the area instruct you to do so. Hospitals or health care facilities may be using RF monitoring equipment.

1.9 Aircraft

Turn your FALCOM C2D-SI OFF before boarding any aircraft.

Use it on the ground only with crew permission.

Do not use it in the air.

To prevent possible interference with aircraft systems, Federal Aviation Administration (FAA) regulations require you to have permission from a crew member to use your modem while the plane is on the ground. To prevent interference with cellular systems, local RF regulations prohibit using your modem whilst airborne.

1.10 Children

Do not allow children to play with your FALCOM C2D-SI modem. It is not a toy. Children could hurt themselves or others (by poking themselves or others in the eye with the antenna, for example). Children could damage the modem or make calls that increase your modem bills.

1.11 Blasting areas

To avoid interfering with blasting operations, turn your unit OFF when in a “blasting area” or in areas posted: „turn off two-way radio“. Construction crew often use remote control RF devices to set off explosives.

1.12 Potentially explosive atmospheres

Turn your modem FALCOM C2D-SI **OFF** when in any area with a potentially explosive atmosphere. It is rare, but your modem or its accessories could generate sparks. Sparks in such areas could cause an explosion or fire resulting in bodily injury or even death.

Areas with a potentially explosive atmosphere are often, but not always, clearly marked. They include fuelling areas such as petrol stations; below decks on boats; fuel or chemical transfer or storage facilities; and areas where the air contains chemicals or particles, such as grain, dust or metal powders.

Do not transport or store flammable gas, liquid or explosives, in the compartment of your vehicle which contains your modem or accessories.

Before using your modem in a vehicle powered by liquefied petroleum gas (such as propane or butane) ensure that the vehicle complies with the relevant fire and safety regulations of the country in which the vehicle is to be used.

1.13 Non-ionising radiation

As with other mobile radio transmitting equipment users are advised that for satisfactory operation and for the safety of personnel, it is recommended that no part of the human body be allowed to come too close to the antenna during operation of the equipment.

The radio equipment shall be connected to the antenna via a non-radiating 50 Ohm coaxial cable.

The antenna shall be mounted in such a position that no part of the human body will normally rest close to any part of the antenna. It is also recommended to use the equipment not close to medical devices as for example hearing aids and pacemakers.

2 Safety standards

This GSM modem complies with all applicable RF safety standards.

The embedded GSM modem meets the safety standards for RF receivers and the standards and recommendations for the protection of public exposure to RF electromagnetic energy established by government bodies and professional organizations, such as directives of the European Community, Directorate General V in matters of radio frequency electromagnetic energy.

3 Technical data

General specifications	
Dimensions	64 mm x 41.5 mm x 12.5mm (B x W x H) (for more details see chapter 6 Housing)
Weight	43g

Table 2: General specifications

C2D-SI-900/1800 power consumption

GPS on	VC3 3.3 V DC \pm 5 %			
/GSM off	Max. 65 mA continuous mode			
GPS off /GSM on	VC5 5.0 V DC \pm 5 %			
	Average current (in mA at 5 V nominal):			
	900	1800	MHz	GSM band
	14	14	mA	in idle mode (base station sends at -85 dBm)
	167	135	mA	in transmit mode at power level 7/3
	220	189	mA	in transmit mode at power level 5/0
Serial interface is applied and working.				

Table 3: Power supply and current consumption (for C2D-SI) at 5 V DC

C2D-SI-900/1800-G10 power consumption

GPS on	VC3 3.3 V DC \pm 5 %			
/GSM off	Max. 65 mA continuous mode			
VC5 5.0 V DC \pm 5 %				
Average current (in mA at 5 V nominal):				
GPS Off /GSM on	900	1800	MHz	GSM band
	16	16	mA	in idle mode (base station sends at -85 dBm)
	185	135	mA	in transmit mode at power level 7/3
	237	183	mA	in transmit mode at power level 5/0
GPS off /GPRS on	441		mA	in transmit/receive mode at maximum power level 5 (3 x downstream +2 x upstream using Coding Scheme 4 (CS-4))
Serial interface is applied and working.				

Table 4: Power supply and current consumption (for C2D-SI-G10) at 5 V DC

Temperature limits	
Operation/Full GSM specification compliant	-20°C to +55°C
Transportation	-40°C to +70°C
Storage	-30°C to +85°C

Table 5: Temperature limits

Interface specifications	
Interface A	60pin connector AMP 177984-2 ¹⁾
Interface B	GPS 50 Ω, MCX female
Interface C	GSM 50 Ω, MC-Card (Radiall)
Interface D	SIM card reader for small SIM cards (3V)
E	Holes for fixing after mounting Recommended screws: 2,2 x 16 mm The screw could be longer and it depends on the customer's application

Table 6: Interface specifications

- 1) 60 pin connector AMP 177984-2
Counterpart for application²⁾: AMP 177983-2
- 2) The module FALCOM FALCOM C2D-SI is for flat mounting and the space between the highest point of the module and its bottom is 2 mm.

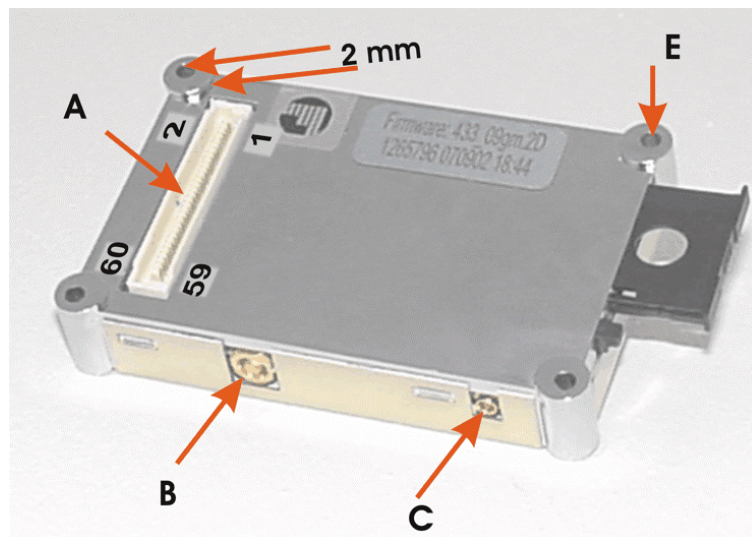

Figure 2: Interfaces of the C2D-SI modem

3.1 Pin configuration of the 60 pin connector

PIN	GSM modem	DESCRIPTION	LEVEL
1	MIC P2 a	Microphone 2 positive	differential input
2	MIC N2 a	Microphone 2 negative	differential input
3	SPK P2 a	Speaker 2 positive	differential output
4	SPK N2 a	Speaker 2 negative	differential output
5	DTR0	Data Terminal Ready	CMOS 2,8 V input
6	CTS0	Clear To Send	CMOS 2,8 V output
7	DSR0	Data Set Ready	CMOS 2,8 V output
8	RTS0	Ready To Send	CMOS 2,8 V input
9	RI0	Ring Indicator	CMOS 2,8 V output
10	DCD0	Data Carrier Detect	CMOS 2,8 V output
11	SOFT ON	Turn phone on	CMOS 2,8 V input
12	RING PWM	Ringer Interface	CMOS 2,8 V output
13	RX	Receive Data	CMOS 2,8 V output
14	TX	Transmit Data	CMOS 2,8 V input
15	Reserved	Please do not connect !	
16	RESET GSM	Reset-Active Low	SCHMITT-Trigger
17	MIC N1 a	Microphone 1 negative	differential input
18	VCCRTC	RTC back-up battery supply	+2 .. 2.75 V input
19	SPK N1 a	Speaker 1 negative	differential output
20	MIC P1 a	Microphone 1 positive	differential input
22	SPK P1 a	Speaker 1 positive	differential output
23	VC5	Power supply	5 V DC
24	VC5	Power supply	5 V DC

PIN	GSM modem	DESCRIPTION	LEVEL
25	VC5	Power supply	5 V DC
26	VC5	Power supply	5 V DC
27	GPIO1 (GSM)	General purpose	CMOS 2,8 V inp./out.
28	VC5	Power supply	5 V DC
30	EN	Internal Power enable	CMOS 2,8 V input
31	GROUND	-	-
32	GROUND	-	-
33	GROUND	-	-
34	GROUND	-	-
35	SIMPREK	SIM present for external card	CMOS 2,8 V input
36	Reserved	Please do not connect!	
37	SIMDATA	SIM Data	CMOS 2,8 V inp./out.
38	SIMVCC	SIM Card power supply	3 V DC output
39	SIMRST	SIM Reset	output
40	SIMCLK	SIM Clock	output

Table 7: Pin configuration AMP 177984-2

PIN	GPS receiver	DESCRIPTION	LEVEL
21	GPIO15	Reserved	CMOS 3,3 V inp./out.
29	GPIO10	Reserved	CMOS 3,3 V inp./out.
41	TMARK	1 PPS Time Mark Output	CMOS 3,3 V output
42	BOOTSELECT	For firmware update	active high
43	GROUND	-	-
44	GROUND	-	-
45	SDI2	Serial 2 Data Input	CMOS 3,3 V input
46	GROUND	-	-

PIN	GPS receiver	DESCRIPTION	LEVEL
47	GROUND	-	-
48	SDO2	Serial 2 Data Output	CMOS 3,3 V output
49	SDO1	Serial 1 Data Output	CMOS 3,3 V output
50	SDI1	Serial 1 Data Input	CMOS 3,3 V input
51	GPIO6	Reserved	CMOS 3,3 V input/output
52	GROUND	-	-
53	GPIO5	Reserved	CMOS 3,3 V inp./out.
54	GPIO A	Reserved	CMOS 3,3 V inp./out.
55	M-RST	Master Reset Input	active low
56	GPIO7	Reserved	CMOS 3,3 V inp./out.
57	VBATT_RTC	Battery Backup Input	3 V DC
58	3,3 V DC	Primary DC Power	3,3 V DC
59	Reserved	Reserved for Preamplifier Power.(see page 27)	(3,3 V DC - 6 V DC)
60	3,3V DC	Primary DC Power	3,3 V DC

Table 8: Pin configuration AMP 177984-2, GPS receiver

3.1.1 Determining the External Equipment Type

Before you connect the C2D-SI module (DCE unit) to external equipment, you need to determine if the external hardware serial ports are configured as DTE or DCE.

The terms DTE (Data Terminal Equipment) and DCE (Data Communications Equipment) are typically used to describe serial ports on devices. Computers (PCs) generally use DTE connectors and communication devices such as modems and DSU/CSU devices generally use DCE connectors. As a general rule, DTE ports connect to DCE ports via straight through pinned cables. In other words, a DTE port never connects directly to another DTE port. Similarly, a DCE port never connects directly to another DCE port. The signalling definitions were written from the perspective of the DTE device; therefore, a Receive Data signal becomes an input to DTE but an output from DCE.

The C2D-SI is designed for use as a DCE unit. Based on the aforementioned conventions for DCE-DTE connections it communicates with the customer application (DTE) using the following signals:

GSM Terminal (DCE)	to	Application (DTE)
TX	←-----	TXD
RX	-----▶	RXD
RTS0	←-----	RTS
CTS0	-----▶	CTS
DTR0	←-----	DTR
DSR0	-----▶	DSR
DCD0	-----▶	DCD
RI0	-----▶	RING

Table 11: The signaling definitions between DTE and DCE.

4 GSM modem

4.1 General

4.1.1 GSM capability

E-GSM and DCS (GSM ETSI Phase I and II)

4.1.2 GPRS capability

The FALCOM C2D-SI is GPRS class B, class 10 capable.

It supports PBCCH/PCCCH; coding schemes: CS1 to CS4 and it is compliant with SMG32 – Release 97.

Note that the GPRS functionality is a subject of the implementation of the current GSM/GPRS firmware.

4.1.3 GSM data services

300....14400 BPS, asynchronous, transparent and non-transparent (V.21, V.22, V.23, V.22bis, V.26ter, V.32, V.34, V.110)

4.1.4 RF characteristics

Receiver	
EGSM Sensitivity	< -104 dBm
DCS Sensitivity	< -100 dBm
Selectivity @ 200 kHz	> +9 dBc
Selectivity @ 400 kHz	> +41 dBc
Dynamic range	62 dB
Intermodulation	> -43 dBm
Co-channel rejection	≥ 9 dBc

Table 9: Receiver

Transmitter	
Maximum output power (EGSM)	33 dBm ± 2 dB
Maximum output power (DCS)	30 dBm ± 2 dB

Transmitter	
Minimum output power (EGSM)	5 dBm \pm 5 dB
Minimum output power (DCS)	0 dBm \pm 5 dB
H2 level	\leq 30 dBm
H3 level	\leq 30 dBm
Noise in 925....935 MHz	\leq 67 dBm
Noise in 935....960 MHz	\leq 79 dBm
Noise in 1805....1880 MHz	\leq 71 dBm
Phase error at peak power	$<$ 5° RMS
Frequency error	\pm 0.1 ppm max

Table 10: Transmitter

4.1.5 SIM card reader

Internal, for small SIM cards (3 V)
 External, 10...15 cm maximum cable length

4.1.6 RS 232

RS 232	
2.8 V	RX, TX, RTS,CTS, DTR, DSR, DCD, RI
300....115200	Baud rates for serial link (2400...19200 with auto-bauding)

Table 11: RS 232

4.1.7 Possible external devices

Audio	
2 K Ω differential	Microphone 1 impedance
2 V	Microphone 1 bias voltage
0,5 mA	Microphone 1 input current
2 K Ω differential	Microphone 2 impedance

Audio	
2 V	Microphone 2 bias voltage
0,5 mA	Microphone 2 input current
$> 50 \Omega (<1nF)$	Speaker 1 impedance
$> 50 \Omega (<1nF)$	Speaker 2 impedance

Table 12: Audio

4.2 Special functionality pins

Table 7 and table 8 show the pin-configuration of the AMP 177984-2. In these tables CMOS means 2.8 V. You may use a 3 V or 3.3 V CMOS level logic (never 5 V) on the 2.8 V I/O's. However, it is required to add serial resistance on all the lines you will use (typical value: from 4.7 to 10 K Ω).

There are a few pins needed for the operation of the module. The handling of pins is described as follows.

Pin 30 (EN)

This signal is an input of the internal voltage regulator.

- Pull to LOW to switch the voltage regulator off (for minimum current consumption).
- Pull to HIGH or leave the signal open if EN is not used.

Pin 27 (GPIO 1 → Flash_LED)

This signal can be used to show the current status of the module:

- If GPIO 1 is LOW then the module is off.
- If it is continuously HIGH then module is on, but not registered into a network.
- If GPIO 1 is flashing in a 2sec period then the module is on and registered into a network.
- If it flashes in a 1sec period then the module is on and a call is in progress (incoming or outgoing).

GPIO 1 can be an input into a controller (here it needs to be driven by an open collector circuit) or used together with a LED (see figure 3).

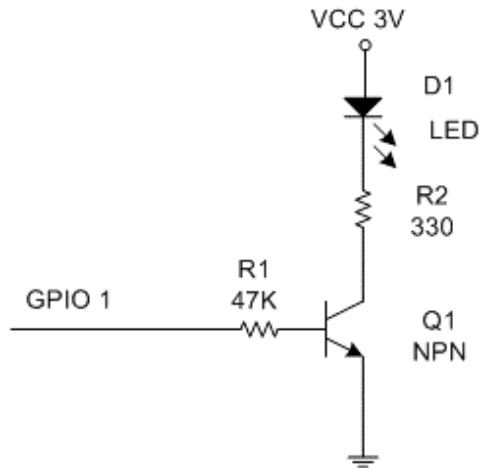

Figure 3: PIN 27

Pin 35 (SIMPRESK)

This signal needs to be driven by an open collector circuit. It is used by the module firmware to detect a SIM card exchange when the module is online. A high to low transition means SIM card is inserted and the module will be able to accept the AT+CPIN command. A low to high transition means SIM card has been removed, the module will de-register from the network and show the unsolicited error code CME ERROR: 10.

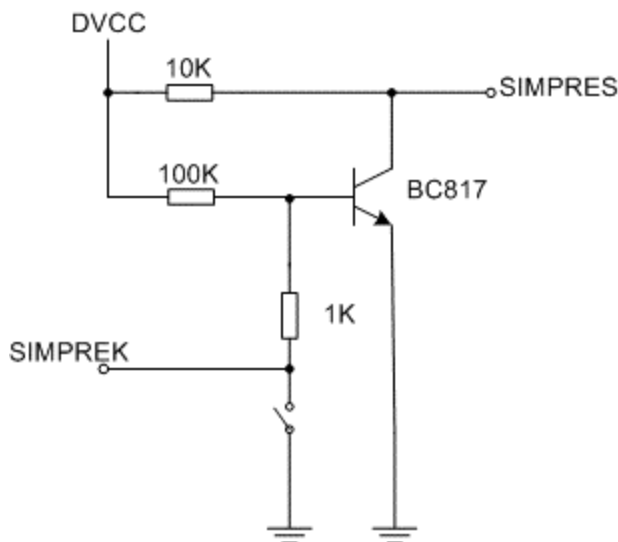

Figure 4: Sample application for SIMPREK

Pin 16 (RESET GSM)

This signal needs to be driven by an external open collector circuit.

- To issue a hardware reset pull the signal to LOW for a minimum of 100ms.
- Pull the signal to HIGH or leave it open for normal operation.

Pin 11 (SOFT_ON)

This signal needs to be driven by an external open collector circuit.

- For switching the module on (external power must be connected!) set the SOFT_ON signal to HIGH for approx. 3sec. The signal can be left HIGH until module shall be switched off.
- For switching the module off the commands AT+CPOF or AT+CFUN=0 have to be issued.
 - If SOFT_ON is HIGH then only the RF part of the module is off, but the AT command set is still working (AT+CFUN=1 can be used to wake up the RF part again) the Flash_LED stays HIGH.
 - If SOFT_ON is LOW then the complete GSM engine goes OFF the Flash-LED goes LOW. Some small power consumption will be still there, use the EN pin to avoid that.

It is not recommended to switch the module on and off by means of the power supply (e. g. by tying the SOFT_ON constantly to HIGH). The module will so have no possibility to de-register correctly from the network and this will cause problems at the next attempt to register.

Pin 18 (VCCRTC)

This pin is used as a back-up power supply for the internal Real Time Clock of GSM/GPRS engine. The RTC is supported by the C2D-SI module when powered on but a back-up power supply is needed to save date and time when the module is switched off (see AT+CCLK to set the date and time). If the RTC is not used, this pin can be left open.

Name	Pin number	I/O	I/O type	Description
VCCRTC	18	I/O	Supply	RTC Back-up supply

❖ **Operating condition**

Parameter	Condition	Min	Max	Unit
Input voltage		2	2.75	V
Input current	V _{cc} = 0V; t° = 25°C VCCRTC = 2.5V	2	3	µA
Input current	V _{cc} =0V; t° = -20°C /55°C VCCRTC = 2.5V		10	µA
Output voltage		2.4	2.75	V
Output current			2	mA

❖ **Typical implementation of pin 18 (VCCRTC)**

1. Capacitor

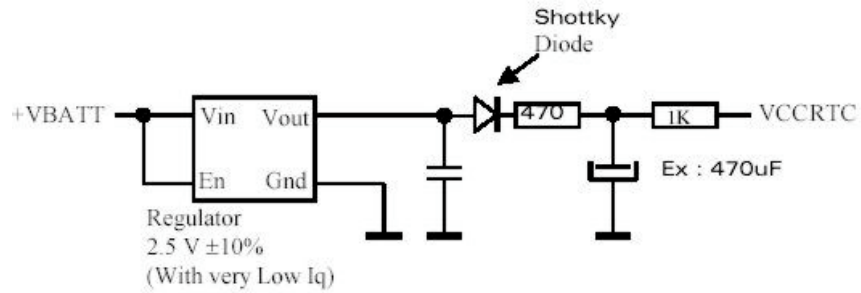

Estimated range with 470 µF Capacitor : ~30 seconds.

2. Super capacitor

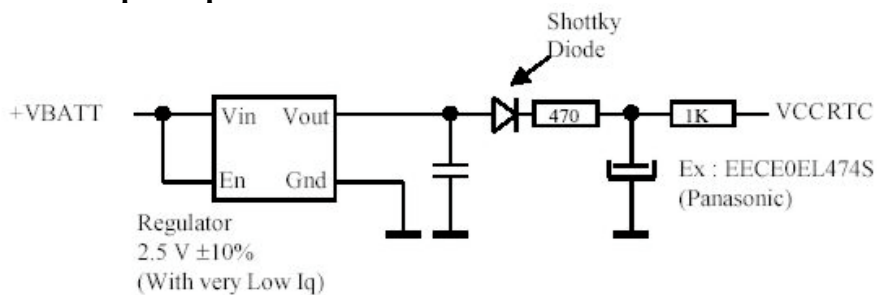

Estimated range with 0.47 Farad Gold Cap : 2 hours min.

Note : the Gold Capacitor maximum voltage is 2.5 V.

3. Battery cell with regulator

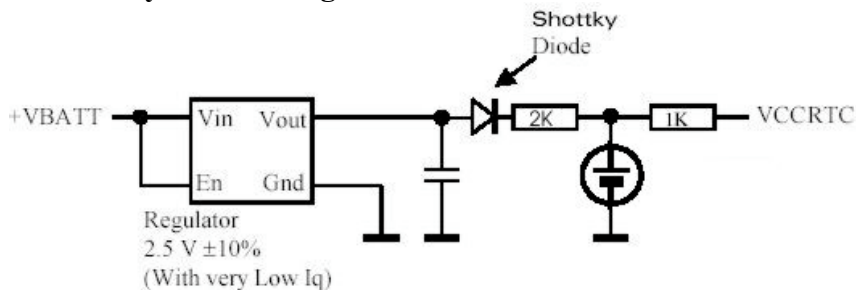

Estimated range with 2 mAh battery rechargeable battery : ~3 days.

Warning :

Before battery cell assembly insure that cell voltage is lower than 2,75V to avoid any damage to the C2D-SI module.

4. Non Rechargeable battery

This is the less recommended solution

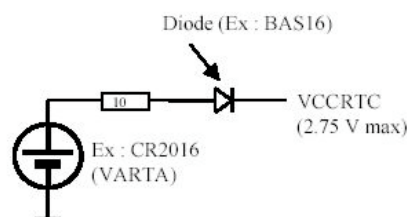

Estimated range with 85 mAh battery : 4000 h minimum

Note :

The “non rechargeable battery” is always active, except when the module is ON.

4.2.1 Firmware download procedure

On the Falcom’s homepage the user can find a zip file which includes the GSM firmware (Loader software) as well as the “readme” text file which shows the download (update) steps.

www.falcom.de/Service/firmware

4.2.2 Resetting the GSM module by AT+CFUN=1,1

If the GSM software is still running, while the user feels the need to reset the module, AT+CFUN=1,1 can be used. This will de-register the modem from the network and bring it into the state before the PIN could be entered. The Flash_LED pin shortly toggle to OFF and back to ON again to show the progress.

4.3 GSM 07.05 and 07.07 commands

The GSM modem of the FALCOM C2D-SI is controlled by an advanced set of AT commands. In the following list there is a short overview of these commands. For further information it is recommended to read the ETSI GSM recommendation or have a look at the FALCOM homepage :

www.falcom.de/Service/Manuals

4.3.1 General AT commands

Command	Meaning	Command	Meaning
+++	Switch to command mode when connected	AT&C1	DCD matches state of the remote modem's data carrier
ATA	Answer call	AT&D0	Ignore DTR signal
ATDx	Dial data number „x”	AT&D1	At DTR-> OFF: Switches from data to command mode
ATDx;	Dial voice number „x”	AT&D2	At DTR-> OFF: Clear down the call
ATE0	Disable command echo	AT&W	Store current configuration
ATE1	Enable command echo	T+IPR	Select the modem's data rate
ATH	Disconnect existing connection	AT+IFC	Select the modem's local flow control setting
ATO	Return to data mode	AT+VGR	Tune the receive gain
ATS0=n	Go off-hook after n-th ringing signal (n = „1”- „5”)	AT+VGT	Tune the transmit gain
ATS0=0	No automatic answering of calls	AT+VTD	Define DTMF tone duration
ATZ	Load stored profile	AT+VTS	Send DTMF tone
AT&C0	DCD always ON		
AT+CBST	Select the bearer type	AT+CPIN	Enter PIN and query blocks
AT+CCFC	Control the call forwarding supplementary service	AT+CPWD	Change PIN or the supplementary password
AT+CCWA	Control the call waiting supplementary service	AT+CSQ	Display signal quality information
AT+CFUN	Select the functionality level in the modem	AT+CR	Select connection service report

Command	Meaning	Command	Meaning
AT+CGMI	Display manufacturer ID	AT+CRC	Select call service report
AT+CGMM	Display model ID	ATCLIP	Calling line identification presentation
AT+CGMR	Display version of GSM module	AT+CLIR	Control the calling line identification presentation
AT+CGSN	Display serial number (IMEI)	AT+COLP	Control the connected line identification presentation
AT+CREG	Display network registration status	AT+CMEE	Report mobile equipment errors
AT+COPS	Commands relating to network operator selection	AT+CEER	Extend error report

Table 13: General AT commands

4.3.2 SMS AT commands (GSM 07.05)

Command	Meaning	Command	Meaning
AT+CSCA	Service centre address	AT+CMGR	Read message
AT+CSCS	Select TE character set	AT+CMGS	Send message
AT+CSDH	Show test mode parameter	AT+CMGD	Delete message
AT+CSMP	Select text mode parameter	AT+CMGL	List message
AT+CSMS	Select message service	AT+SNMI	New message indication
AT+CPMS	Preferred message storage	AT+CSAS	Save SMS settings
AT+CMGF	Text mode / PDU Mode	AT+CRES	Restore SMS settings

Table 14: SMS AT commands

5 GPS core

5.1 Receiver architecture

The GPS receiver in the FALCOM C2D-SI from FALCOM is a new GPS receiver product that features the SiRFstarII chipset. This complete 12 channel, WAAS-enabled GPS receiver provides a vastly superior position accuracy performance in a much smaller package. The SiRFstarII architecture builds on the high-performance SiRFstarI core, adding an acquisition accelerator, differential GPS processor, multipath mitigation hardware and satellite-tracking engine. The receiver delivers major advancements in GPS performance, accuracy, integration, computing power and flexibility.

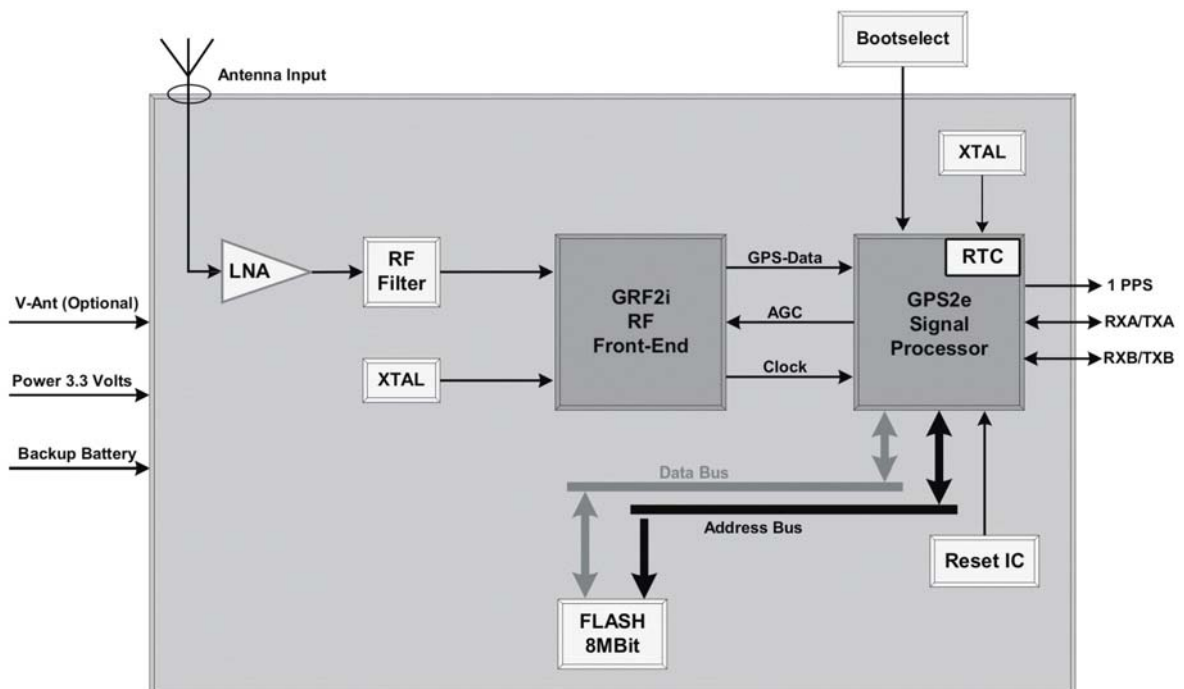

Figure 5: Architecture of the GPS receiver core inside FALCOM C2D-SI

5.2 Technical data

FEATURES

- Integrated 12 parallel channel GPS
- operating voltage: 3.3 VDC +/- 5 %
- power consumption: 220 mW (continuous mode)
- temperature range: -20 to +55°C operation
-40 to +70°C transportation
-25 to +70°C storage
- protocol: SDI1/SDO1: NMEA 4800 baud, Msg.: GLL,
GGA, RMC, VTG, GSV, GSA, ZDA
8 data bits, no parity, 1 stop bit
- RXB/TXB: RTCM, 9600 baud

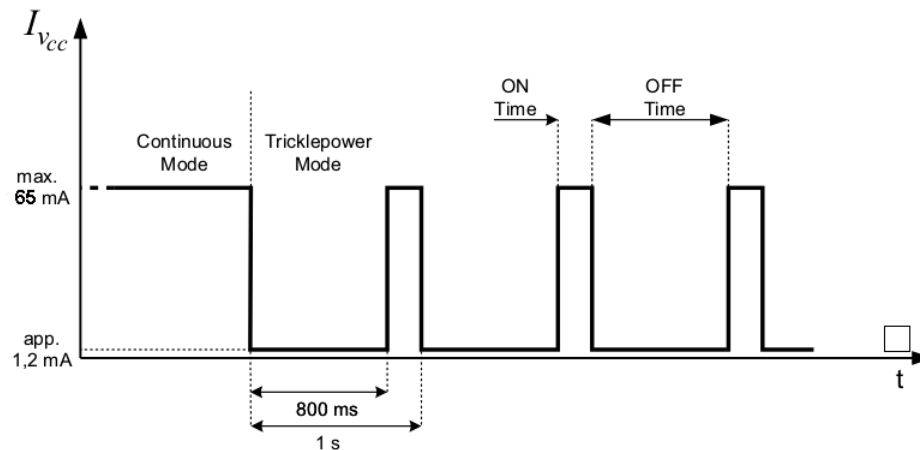

Figure 6: Default settings for the trickle power mode of FALCOM C2D-SI

- trickle power mode: The FALCOM C2D-SI enters the trickle power mode according to figure 6 (**800 ms OFF Time and 200 ms ON Time**) as soon as valid GPS data are available. As a result the average power consumption is reduced by approximately 80 % (approximately 150 mW). The settings for the trickle power mode can be modified using the SiRFstar demo software. For example if the FALCOM C2D-SI is configured to enter the OnTime mode each 10s for a duration of 200ms the average power consumption can be reduced by approximately 95% (approximately 15mW, ca. 4,8mA at $V_{cc}=3.3V$).

Hint: The power-on scenario in Trickle Power Mode differs from one in continuous

mode. If the module fails to acquire satellites within a given period of time (approx. 150 sec), the module goes into an extended sleep phase. The duration of this sleep phase is approx. 30 sec. After that, the module wakes up, make a reset and tries to acquire satellites. This procedure repeats itself until the GPS receiver can detect satellites.

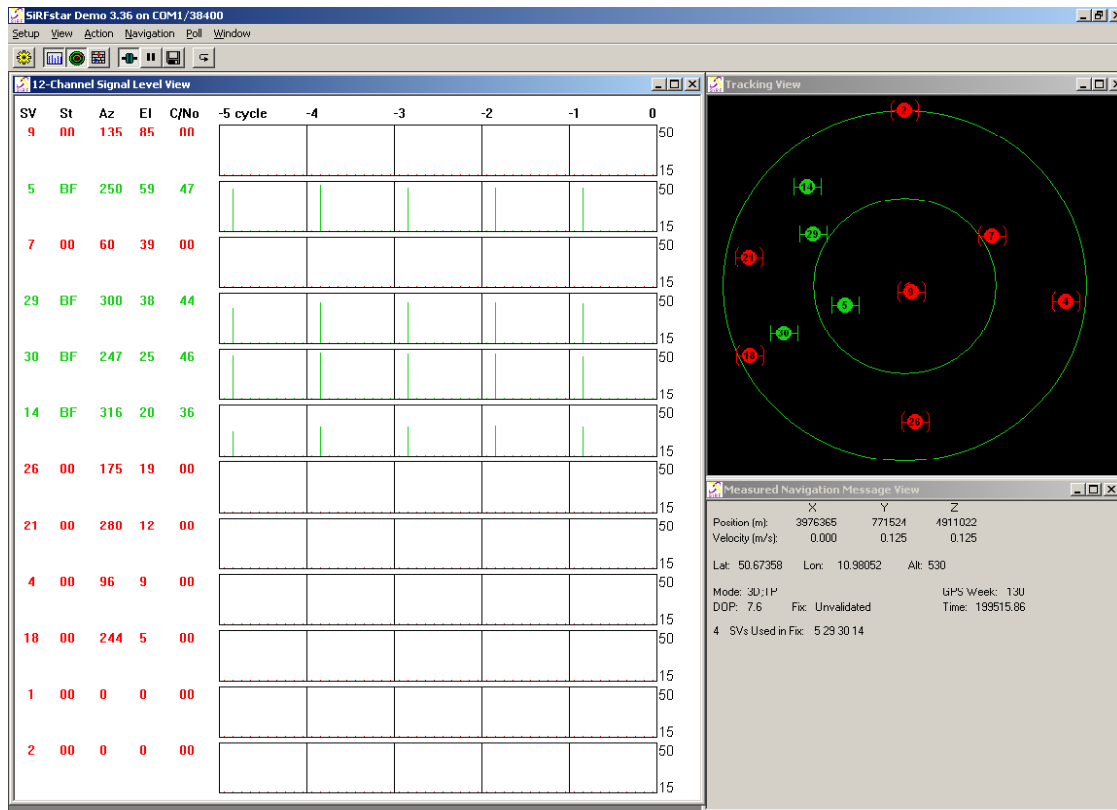

Figure 7: Example of using of the SiRFdemo (FALCOM C2D-SI in trickle power mode)

5.3 Technical description

5.3.1 Technical specification

Electrical Characteristics

1. General

Frequency	L1, 1575.42 MHz
C/A code	1.023 MHz chip rate
Channels	12

2. Accuracy

Position	10 meters CEP without SA
Velocity	0.1 meters/second, without SA
Time	1 microsecond synchronized to GPS time

3. DGPS Accuracy

Position	1 to 5 meters, typical
Velocity	0.05 meters/second, typical

4. Datum

WGS-84

5. Acquisition Rate

Snap start	< 3 sec., average
Hot start	< 8 sec., average
Warm start	< 38 sec., average
Cold start	< 45 sec., average

6. Dynamic Conditions

Altitude	18,000 meters (60,000 feet) max.
Velocity	515 meters/second (1000 knots) max.
Acceleration	4g, max. (g = 9,8m/s)
Jerk	20 meters/second ³ , max.

7. DC Power

Main power	+ 3.3 V DC +/- 5 %
Continuous mode	65mA typical at 3.3 V DC
Backup battery power	typical +3V DC \pm 0.25 V

8. Serial Port

Electrical interface	Two full duplex serial communication, CMOS interfaces.
Protocol messages	SiRF binary and NMEA-0183, version 2.20 with a baud rate selection. SiRF binary position, velocity, altitude, status and control NMEA CGA, GLL, GSA, GSV, RMC and VTG.
DGPS protocol	RTCM SC-104, version 2.00, type 1,5 and 9.

9. Time 1PPS Pulse (T-Mark)

Level	CMOS
Pulse duration	100 ms
Time reference	At the pulse positive edge Measurements Aligned to GPS second, +/- microsecond

5.4 Hardware interface

5.4.1 Configuration and timing signals

- M-RST (Pin 55) This pin provides an active-low reset input to the board. It causes the board to reset and start searching for satellites. Reset is an optional input and, if not utilized, it may be left open.
- T-Mark (Pin 41) This pin provides 1 pulse per second output from the board, which is synchronized to within 1 microsecond of GPS time. The output is a CMOS level signal.
This is not available in trickle power mode.
- Bootselect (Pin 42) This pin is setting high for programming the flash of the FALCOM C2D-SI (for instance updating to a new firmware for the GPS receiver in the FALCOM C2D-SI).

5.4.2 Serial communication signals

The board supports two full duplex serial channels. All four connections are at CMOS levels, all support variable baud rates and all can be controlled from the appropriate screens in SiRFdemo software. You can directly communicate with a PC serial port.

- SDI1 (Pin 50) This is the main receiving channel and is used to receive software commands to the board from SiRFdemo software or from user written software.
- SDI2 (Pin 45) This is the auxiliary receiving channel and is used to input differential corrections to the board to enable DGPS navigation.
- SDO1 (Pin 49) This is the main transmitting channel and is used to output navigation and measurement data to SiRFdemo or user written software.
- SDO2 (Pin 48) For user's application.

5.4.3 DC input signals

VCC (Pin 58 and 60) This is the main DC power supply for 3,3 V powered board FALCOM C2D-SI. Connect both pins.

VANT (Pin 59) This pin is reserved for an external DC power supply for an active antenna (e.g.: 5 V active antenna). With a change of the PCB assembling this pin can be activated.

Default: The GPS core in the FALCOM C2D-SI has to be connected with active 3 V GPS antenna with max. current of 20mA. The antenna voltage is provided by the internal power management

GND GND provides the ground for the GPS core. (Pins 43, 44, 46, 47 and 52) Connect all GND pins.

5.4.4 General purpose input/output (Pin 51, 53, 54 and 56)

Several I/O's of the CPU are connected to the hardware interface connector of the FALCOM C2D-SI. They are reserved for customer specific applications.

5.5 Software interface

The GPS core in the FALCOM C2D-SI supports NMEA-0183 and SiRF binary protocols. A short description of these protocols are provided herein. For more detailed information please refer to the SiRFstarII message set specification available in the section "[service/manuals](#)" of the FALCOM homepage.

5.5.1 SiRF binary data message

Hex	ASCII	Name	Description
0 x 02	2	Measured Navigation Data	Position, velocity and time
0 x 03	3	True Tracker Data	Not implemented
0 x 04	4	Measured Tracking Data	Satellite and C/No information
0 x 05	5	Raw Track Data	Not supported by SiRFstarII
0 x 06	6	SW Version	Receiver software
0 x 07	7	Clock Status	Current clock status

Hex	ASCII	Name	Description
0 x 08	8	50 BPS Subframe Data	Standard ICD format
0 x 09	9	Throughput	Navigation complete data
0 x 0A	10	Error ID	Error coding for message failure
0 x 0B	11	Command Acknowledgment	Successful request
0 x 0C	12	Command Nacknowledgment	Unsuccessful request
0 x 0D	13	Visible List	Auto Output
0 x 0E	14	Almanac Data	Response to Poll
0 x 0F	15	Ephemeris Data	Response to Poll
0 x 10	16	Test Mode 1	For use with SiRFtest (Test Mode 1)
0 x 11	17	Differential Corrections	Received from DGPS broadcast
0 x 12	18	OkToSend	CPU ON/OFF (Trickle Power)
0 x 13	19	Navigation Parameters	Response to Poll
0 x 14	20	Test Mode 2	Additional test data (Test Mode 2)
0 x 1C	28	Nav. Lib. Measurement Data	Measurement Data
0 x 1D	29	Nav. Lib. DGPS Data	Differential GPS Data
0 x 1E	30	Nav. Lib. SV State Data	Satellite State Data
0 x 1F	31	Nav. Lib. Initialization Data	Initialization Data
0 x FF	255	Development Data	Various status messages
0 x 55	85	Transmit Serial Message	User definable message
0 x 80	128	Initialize Data Source	Receiver initialization and associated parameters
0 x 81	129	Switch to NMEA Protocol	Enable NMEA message, output rate and baud rate
0 x 82	130	Set Almanac (upload)	Sends an existing almanac file to the receiver
0 x 84	132	Software Version (Poll)	Polls for the loaded software version

Hex	ASCII	Name	Description
0 x 85	133	DGPS Source Control	DGPS correction source and beacon receiver information
0 x 86	134	Set Main Serial Port	Baud rate, data bits, stop bits and parity
0 x 87	135	Switch Protocol	Obsolete
0 x 88	136	Mode Control	Navigation mode configuration
0 x 89	137	DOP Mask Control	DOP mask selection and parameters
0 x 8A	138	DGPS Mode	DGPS mode selection and timeout value
0 x 8B	139	Elevation Mask	Elevation tracking and navigation masks
0 x 8C	140	Power Mask	Power tracking and navigation masks
0 x 8D	141	Editing Residual	Not implemented
0 x 8E	142	Steady-State Detection not used	Not implemented
0 x 8F	143	Static Navigation	Configuration for static operation
0 x 90	144	Poll Clock Status (Poll)	Polls the clock status
0 x 91	145	Set DGPS Serial Port	DGPS port baud rate, data bits, stop bits and parity
0 x 92	146	Poll Almanac	Polls for almanac data
0 x 93	147	Poll Ephemeris	Polls for ephemeris data
0 x 94	148	Flash Update	On the fly software update
0 x 95	149	Set Ephemeris (upload)	Sends an existing ephemeris to the receiver
0 x 96	150	Switch Operating Mode	Test mode selection, SV ID and period
0 x 97	151	Set Trickle Power Parameters	Push to fix mode, duty cycle and on time
0 x 98	152	Poll Navigation Parameters	Polls for the current navigation parameters

Hex	ASCII	Name	Description
0 x A5	165	Set UART Configuration	Protocol selection, baud rate, data bits, stop bits and parity
0 x A6	166	Set Message Rate	SiRF binary message output rate
0 x A7	167	Low Power Acquisition Parameters	Low power configuration parameters
0 x B6	182	Set UART Configuration	Obsolete

Table 15: lists the message list for the SiRF output messages

5.5.2 NMEA data message

The SiRFstarIIe evaluation receiver is capable of outputting data in the NMEA-0183 format as defined by the National Marine Electronics Association (NMEA), Standard for Interfacing Marine Electronic Devices, Version 2.20, January 1, 1997. See “Using the SiRFdemo Software” for instructions on using NMEA.

NMEA output messages table 16 lists each of the NMEA output messages supported by the SiRFstarIIe evaluation receiver and a brief description.

Option	Description
GGA	Time, position and fix type data.
GLL	Latitude, longitude, UTC time of position fix and status.
GSA	GPS receiver operating mode, satellites used in the position solution and DOP values.
GSV	The number of GPS satellites in view satellite ID numbers, elevation, azimuth and SNR values.
MSS	Signal-to-noise ratio, signal strength, frequency and bit rate from a radio-beacon receiver.
RMC	Time, date, position, course and speed data.
VTG	Course and speed information relative to the ground.

Table 16: NMEA Output Messages

Message	MID ¹	Description
SetSerialPort	100	Set PORT A parameters and protocol
Navigation Initialization	101	Parameters required for start using X/Y/Z ²
SetDGPSPort	102	Set PORT B parameters for DGPS input
Query/Rate Control	103	Query standard NMEA message and/or set output rate
LLANavigation Initialization	104	Parameters required for start using Lat/Lon/Alt ³
Development Data On/Off	105	Development Data messages On/Off
MSK Receiver Interface	MSK	Command message to a MSK radio-beacon receiver.

Table 17: NMEA input messages

1. Message Identification (MID).
2. Input co-ordinates must be WGS84.
3. Input co-ordinates must be WGS84.

Note: NMEA input messages 100 to 105 are SiRF proprietary NMEA messages. The MSK NMEA string is as defined by the NMEA 0183 standard.

Start	Payload	Checksum	End Sequence
	Data ²	*CKSUM ³	<CR> <LF> ⁴

Table 18: Transport Message

1. Message Identifier consisting of three numeric characters. Input messages begin at MID 100.
2. Message specific data. Refer to a specific message section for <data>...<data>definition.
3. CKSUM is a two-hex character checksum as defined in the NMEA specification. Use of checksums is required on all input messages.
4. Each message is terminated using Carriage Return (CR) Line Feed (LF) which is \r\n which is hex 0D 0A. Because \r\n are not printable ASCII characters, they are omitted from the example strings, but must be sent to terminate the message and cause the receiver to process that input message.

Note: All fields in all proprietary NMEA messages are required, none are optional. All NMEA messages are comma delimited.

6 Housing

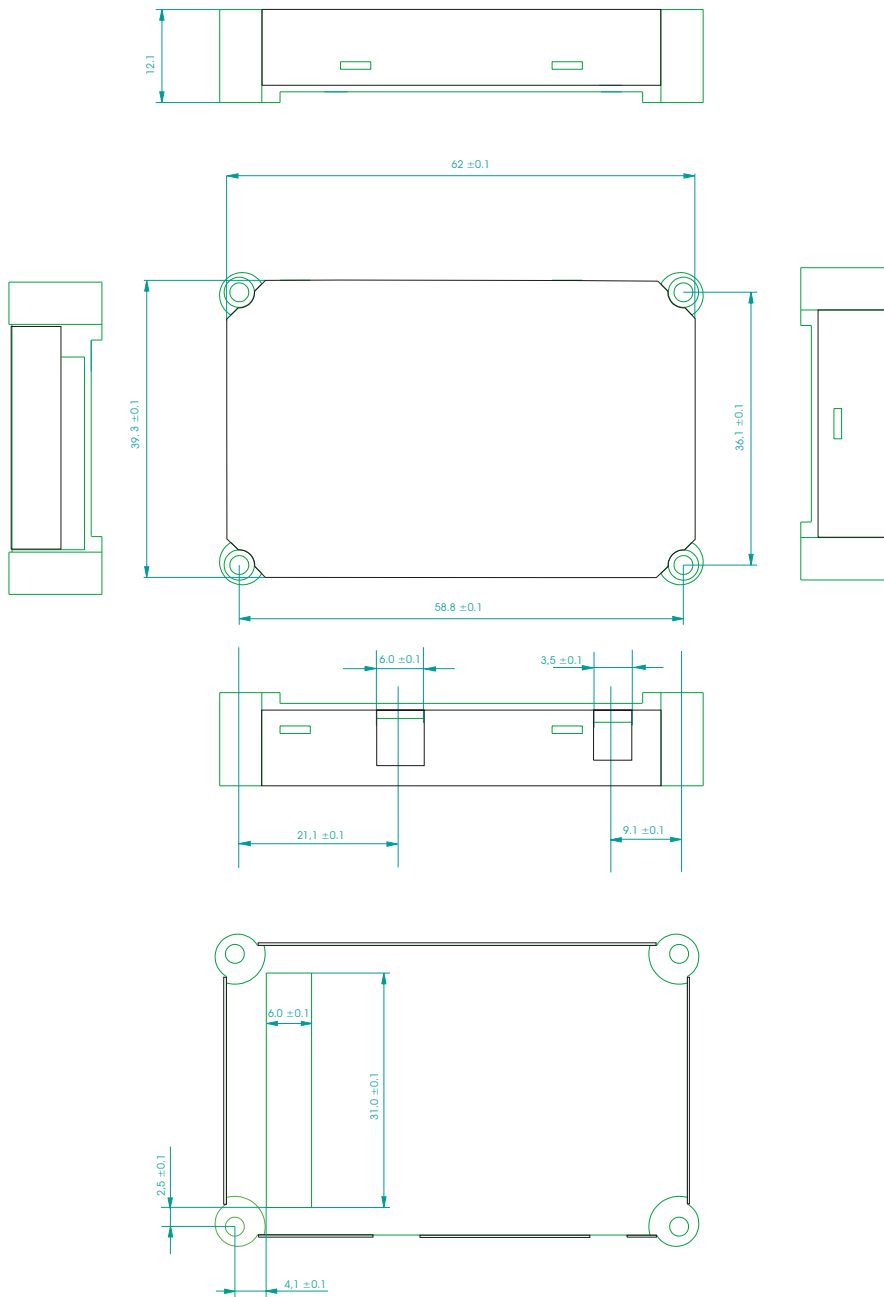

Figure 9: Housing of FALCOM C2D-SI

7 GSM/GPS evaluation kit

The quickest way to get first results with the embedded GSM/GPS module is the activation by the GSM/GPS evaluation kit by means of a terminal program. The FALCOM GSM/GPS EVAL-KIT provides design engineers with all necessary hard- and software information for the creation of embedded applications based on FALCOM embedded modules. It saves design, time and reduces “Time-to-Market” period.



Figure 10: The FALCOM GSM/GPS evaluation board (EVAL-KIT)

Figure 10 shows the GSM/GPS evaluation kit in complete packaging, i. e.

- GSM/GPS evaluation board
- power supply FRIWO type FW 3299 (12V DC/580 mA)
- GPS antenna ANT-006
- RS232 combined cable (GSM/GPS A/GPS B)
- headset with RJ45 plug
- GSM antenna ANT-001
- CD with:
 - “SiRF messages” Input/Output messages for FALCOM GPS-receivers with SiRFStarIIe-chip-set.
 - “SiRF demo” software description
 - “SiRF demo 3.36.exe” software
 - A2D test software
 - evaluation board user manual
 - schematics of the evaluation platform (power supply, external SIM card, serial interface)

The evaluation kit transfers data from GSM module and GPS receiver to two separate RS232 interfaces.

For voice communication by the GSM module there is a headset available.

The data of both modules can be processed by your PC at the same time.

Thus the evaluation kit offers an excellent possibility for development and testing (trials) of your own application on the base of the embedded GSM/GPS modules FALCOM C2D-SI.

8 EMC and ESD requirements

The **ETS 300342-1** standard applies to the FALCOM C2D-SI with regard to EMC and ESD requirements.

Additional requirements in relation to EMC/ESD:

If the FALCOM C2D-SI is being used in cars, the requirements regarding power supply as defined in section 9.6 of the ETS 300342-1 (6/97) standard must be fulfilled.

The connecting cable between the chip card reader and the socket on the FALCOM C2D-SI must be shielded in compliance with EMC requirements.

When using the FALCOM C2D-SI cellular engine with individual handsfree equipment, noise interference may occur.

The FALCOM C2D-SI cellular engine must be connected directly to the ground of the base device.

Note: The device should only be handled in compliance with ESD regulations (grounded, ESD chain, trained personnel).

9 CE conformity

The FALCOM C2D-SI bears the CE symbol. This symbol represents the manufacturer's declaration that the design and implementation of the FALCOM C2D-SI meets the currently valid versions of the following

EU guidelines:	89/336/EC	(EMC guideline)
	73/23/EC	(Low voltage guideline)
	91/263/EC	(Telecommunication devices guideline)

Standards:	EMC:	ETS 300342-1
	Safety:	EN 60950
	GSM network:	TBR 19
		TBR 20