



- **SMART ANTENNA**

- ---
- **FSA03/-LP**

- ---
- *Application Notes*



FSA03-LP

FSA03

Table of contents

1 INTRODUCTION.....	3
1.1 GENERAL.....	3
1.2 TECHNICAL DATA (IN BRIEF).....	3
1.3 SIGNAL LEVELS.....	3
2 SECURITY.....	5
2.1 ELECTROSTATIC DISCHARGE (ESD).....	5
2.2 SOLDERING METHOD.....	5
3 SCHEMATICS.....	6

Version history:

This table provides a summary of the document revisions.

Number	Author	Changes	Modified
1.0.5	F. Beqiri	- USB interface is now supported.	25/03/2011
1.0.4	F. Beqiri	- Picture changed to the FSA03 new hardware version 02b and added for FSA03-LP. Power consumptions for both modules added.	09/11/2010
1.0.3	F. Beqiri	- Maximum input voltage at VBATT pin changed from 4.8 V to 3.6 V - see Table 1 in chapter 1.3. - Baud Rate Option: 38400 bps - Added new Side-view for Hardware revision 02b and higher.	14/09/2010
1.0.2	F. Beqiri	- Added side view	18/02/2010
1.0.1	F. Beqiri	- Updated chapter " Soldering method "	05/05/2009
1.0.0	F. Beqiri	- Initial version	07/10/2008

This confidential document is a property of FALCOM and may not be copied or circulated without previous permission.

1 INTRODUCTION

This application note comprises a brief description of the operation of the FALCOM Smart Antennas FSA03 and FSA03-LP, the Pad-Design and an application circuit.

1.1 General

The Smart Antenna operates from internal ROM.

1.2 Technical data (in brief)

The FSA03 architecture is based on the UBX-G5010 and FSA03-LP on UBX-G6010 the single chip from **u-blox**, for more information about both chips and the u-blox5/6 protocol specifications, please refer to the u-blox website: www.u-blox.com

❖ **Temperature Range:**

- Operation: -40 to 85°C.

❖ **Power Consumption:**

- FSA03: average. 43 mA @ 3.3 V DC; Temp. 23° C.
- FSA03-LP: average. 43 mA @ 3.3 V DC; Temp. 23° C.

❖ **Directive:**

- RoHS compliant (lead-free) and green (no halogens).

❖ **ROM:**

- Output NMEA messages.
 - Baudrate: (default=9600 bps; option=38400),
 - RMC, GGA, GSA, GSV, VTG, GLL

1.3 Signal levels

The names and position of the pads can be seen from the Pad-Design, which is added in chapter 3, “Schematics”. The NC-pins in this schematic are not connected.

Pin name	Level	Function
RES	3.3 V CMOS	Input
TM	3.3 V CMOS	Output
VBATT	1.4 V – 3.6 VDC	Input
GND	0 V	-
VCC	3.3 VDC ±5 %	Input
GND	0 V	-
USB_DM	3.3 V	USB Data Line Minus
USB_DP	3.3 V	USB Data Line Plus
VDD_USB	3.3 VDC ±5 %	Supply voltage for internal USB-Transceiver
TX	3.3 V CMOS	Output
RX	3.3 V CMOS	Input

Table 1: Signal levels and their function

2 SECURITY

This chapter contains important information for the safe and reliable use of the GPS receiver. Please read this chapter carefully before starting to use this GPS receiver.

2.1 Electrostatic Discharge (ESD)

The FSA03/-LP Smart Antennas contain class 1 devices. The FSA03/-LP Smart Antennas contain components that can be damaged or destroyed by electrostatic discharge. When handling the modules, observe the necessary safety precautions against electrostatic discharge (ESD), in accordance with EN 61340-5-1 and the following. The following Electrostatic Discharge (ESD) precautions are recommended:

- *Protective outer garments.*
- *Handle device in ESD safeguarded work area.*
- *Transport device in ESD shielded containers.*
- *Monitor and test all ESD protection equipment.*
- *Treat the FSA03/-LP Smart Antenna as extremely sensitive to ESD.*

2.2 Soldering method

The FSA03/-LP Smart Antennas must be soldered only manually with a soldering iron. The soldered connection / pad design should be in accordance with IPC-A-610D - Chapter 8.2.4.

References

Customers may refer to following IPC standard for more details:

- *IPC-A-610D chapter 8.2.4, "Castellated Terminations".*

Top View

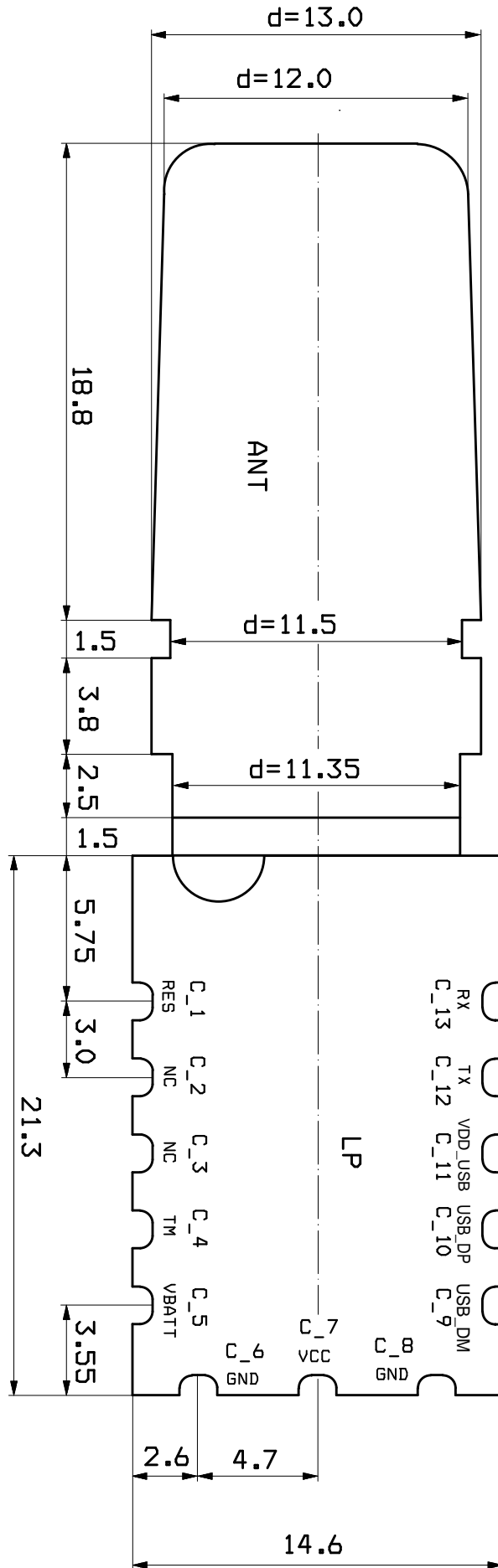

Side View

(Hardware Revision 02b and higher)

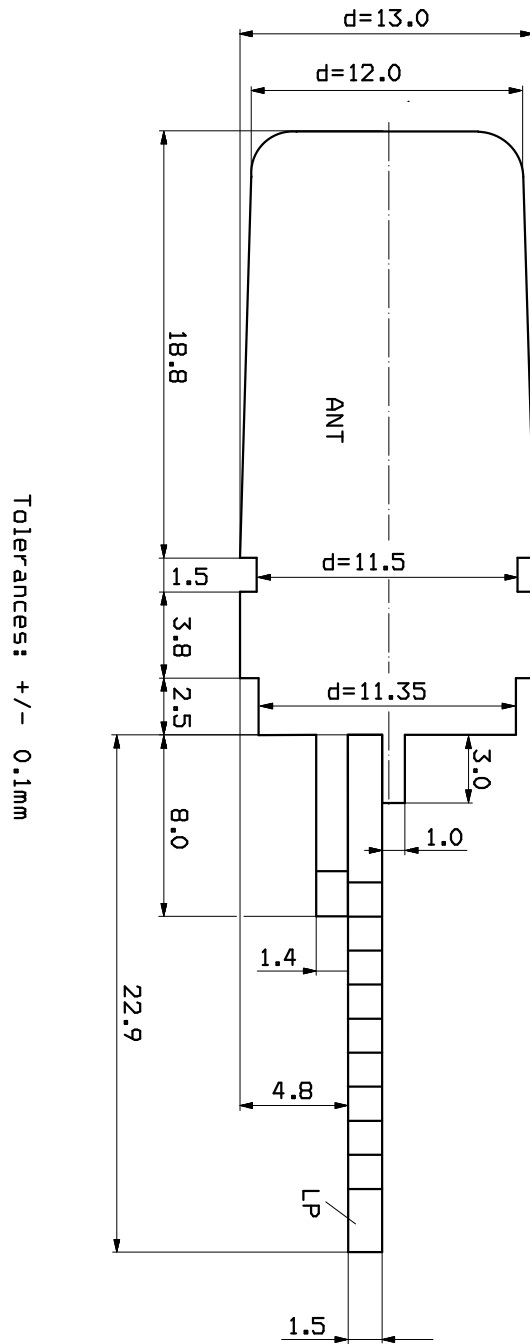

Side View

(Hardware Revision 02a and lower)

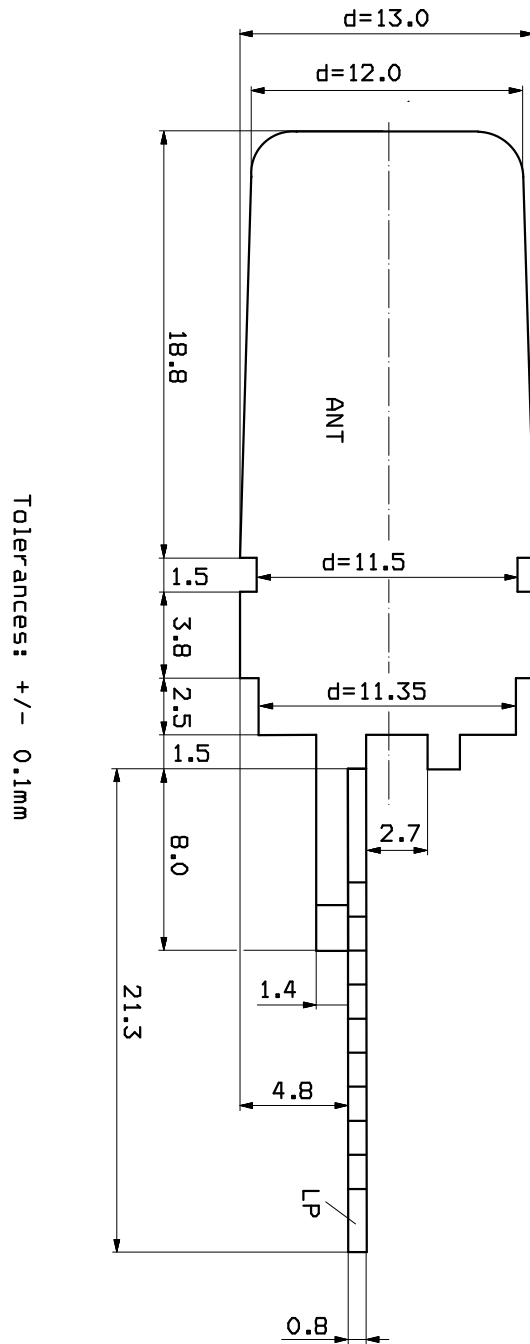

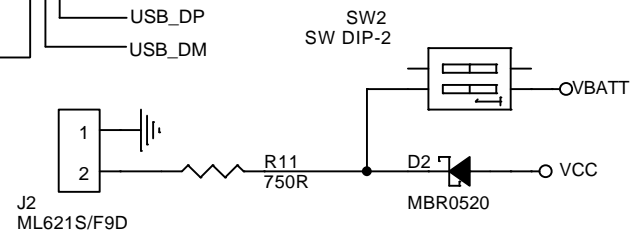
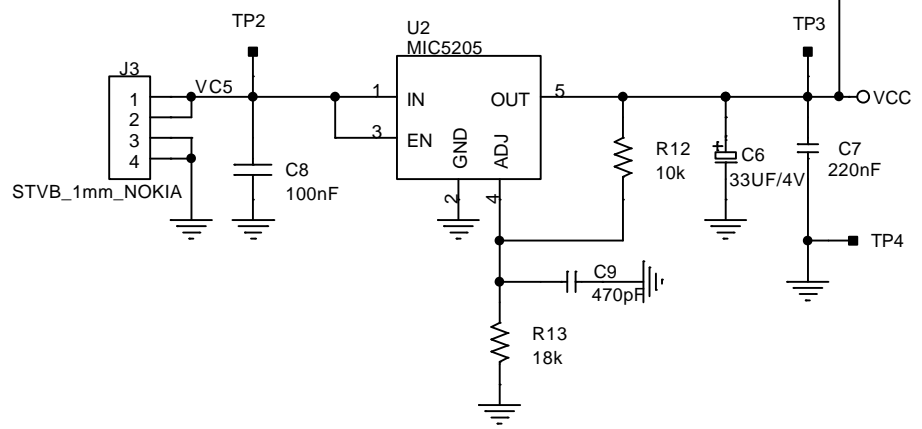
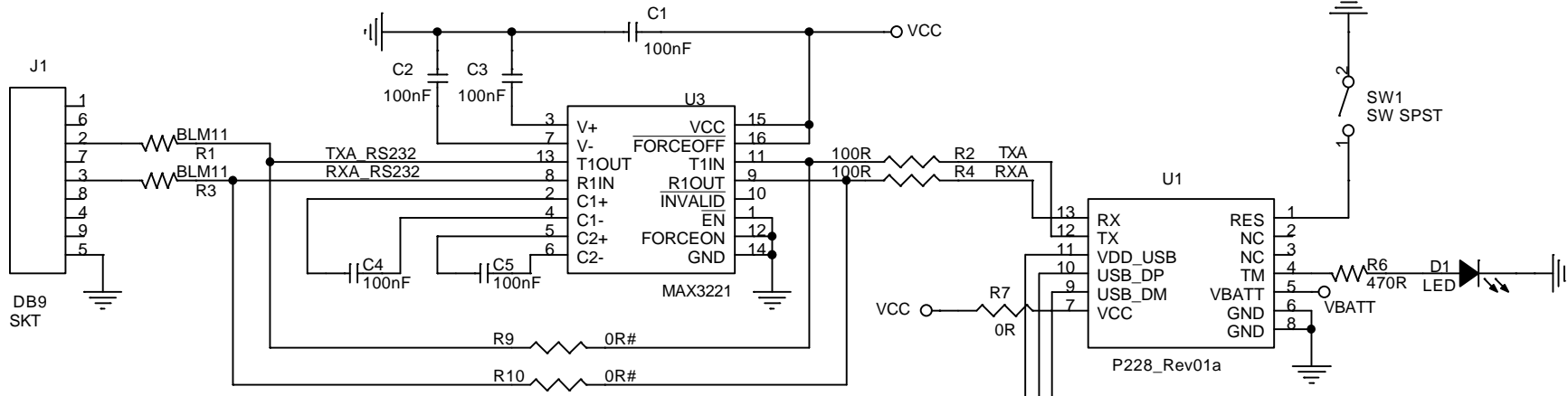

Justiermarken

JUST1

JUST2

TP_N1

FALCOM	
Gewerbering 6	
98704 Langewiesen	
Title	
FSA03 - Application-Circuitry	
Size	Document Number
A	01b
Date:	Monday, August 11, 2008
Sheet	1 of 1